

Full Motion Articulating Heavy Duty TV Wall Mount

For most 37" ~ 90" Flat Panel & Curved TV's & Monitors

LMMA3790

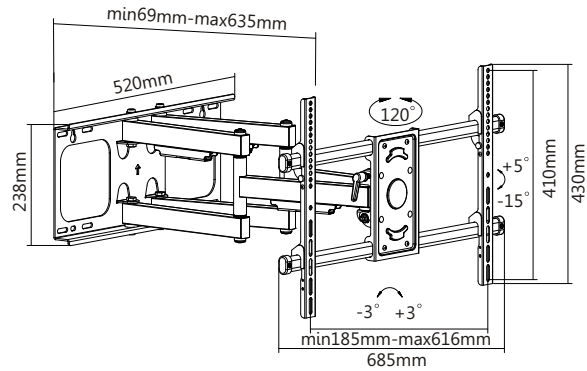
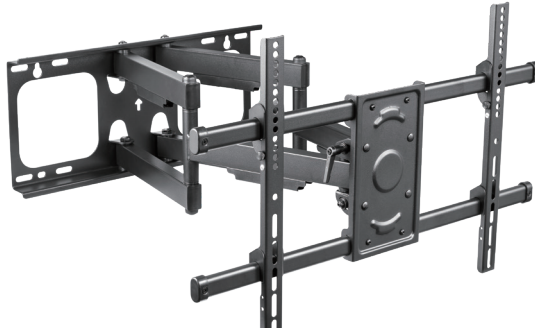

Dimensions (mm)

DESCRIPTION:

Heavy Duty, full motion articulating wall mount is constructed of high gauge steel and designed for most 37"-90" flat panel TVs up-to 65kg/143lbs. This mount allows your TV to be tilted for glare control, optimum viewing angle and can be pulled out from the wall (635mm extension) for angling towards a separate viewing area. The preassembled arm comes complete with cable management and decorative covers for a clean and tidy look.

FEATURES:

- ◆ Heavy Duty Steel Construction
- ◆ Fits most 37" ~ 90" Flat & Curved TVs
- ◆ Supports up to 143lbs
- ◆ Fully Articulating Dual Arm
- ◆ VESA 200x200,400x200,300x300,400x400,600x400
- ◆ UL Listed

INCLUDED ACCESSORIES:

- 1x wall mount plate, 2x monitor bracket
- 1x box wrench, 1x bubble level, 2x locking screws
- 4x each M6x14, M8x16, M6x30, M8x35 screws
- 4x each D8 washers, 5mm & 15mm spacers
- 6x mounting screws, grommets - 4x washers

SPECIFICATION	LMMA3790
Screen Size:	37" ~ 90"
Fits Curved TV:	Yes
Material:	Steel
Weight Capacity:	65kg (143lbs)
Strength Tested:	4 Times Approved
Mounting Hole Pattern:	VESA & Universal
VESA Compatible:	200x200,400x200,300x300,400x400,600x400
Max. Mounting Hole:	600x400
Free Tilting	Quick release lock/unlock for easy positioning
Tilt Range:	+5°~-15°
Swivel Range:	+60°~-60°
Screen Level:	+3°~-3°
Installation:	Solid Wall,Double Stud 406mm/450mm (16"/ 17.7")
Panel Type:	Detachable Panel
Wall Plate Type:	Fixed Wall Plate
Cable Management:	Yes
Bubble Level:	Included Hook-on Bubble Level
Accessory Kit Package:	Normal/Ziplock Polybag,Compartment Polybag
Instruction Manual Included:	Yes
Profile:	69 ~ 635mm (2.7"~25")
Metal Sheet Thickness:	Bracket Arm THK=1.5mm (0.059") Wall Plate THK=3mm (0.12")
Color:	Fine Texture Black
Surface Finish:	Powder Coating
Dimensions:	635x685x430mm (25"x27"x16.9")
Net Weight	9.15kg (20.17lb)
Certification:	UL